

Grandstream Networks, Inc.

HA100

High Availability Kit for UCM6510

Deployment Guide



Table of Contents

INTRODUCTION.....	3
HA100 Deployment Methods.....	4
Powering and Connecting the HA100.....	4
Connecting the HA100 with 2x UCM6510s	5
<i>Setup Requirements</i>	5
<i>UCM6510 and HA100 Connection</i>	5
<i>HA100 Deployment Methods</i>	7
Method 1: Backup and Restore Configuration	7
Method 2: Sync Configuration.....	7
HA100 FUNCTIONALITY	8
UCM6510 Failure Management.....	9
HA100 Failure Management.....	9
Important Notes	9

Table of Figures

Figure 1: High Availability.....	3
Figure 2: Basic Connection Setup of the HA100	4
Figure 3: HA100 Connection with UCM A and UCM B	6
Figure 4: HA100 Functionality.....	8



INTRODUCTION

Thank you for using Grandstream HA100. To meet the requirements of our customers, Grandstream has released the HA100, a module designed to implement the High Availability failover feature for our enterprise grade IP-PBX UCM6510.

It contains a set of external ports and splits each of them into two internal ports: Port A and Port B. The ports on the UCM6510 A and UCM6510 B should be connected to each Port A and Port B respectively. The external ports on the HA100 provide PBX service.

Powered by an advanced hardware platform and revolutionary software functionalities, the connection between the UCM6510 and HA100 offers a breakthrough turnkey solution for converged voice, video, data, fax, security surveillance, and mobility applications out of the box without any extra license fees or recurring costs.



Figure 1: High Availability

HA100 Deployment Methods

Before deploying and configuring the HA100, the unit needs to be properly powered up and connected. This section describes detailed information about the HA100 interfaces and the steps needed for installing and connecting the HA100. This section provides the connection types and steps needed for connecting the HA100 with 2 UCM6510s.

Powering and Connecting the HA100

The external connections are used for the following purposes:

- Powering up the HA100.
- Network connection.
- PSTN lines connection.
- Analog/Fax connection.
- Digital (T1/E1/J1) connections.

Please refer to the following steps for basic connection setup of the HA100:

1. Connect one end of an Ethernet cable to the WAN port of the HA100 and the other end of the cable to the uplink of a hub or switch.
2. Connect 12V power adapter to the 12V power port on HA100 and the other end to a power outlet.



Figure 2: Basic Connection Setup of the HA100

Please refer to the following steps for optional connections on the HA100:

1. **For PSTN connection:** Connect a PSTN cable to the FXO external port on HA100.
2. **For Analog phone/Fax connection:** Connect analog phone or FAX machine to the FXS external port on HA100.
3. **For T1/E1/J1 connection:** Connect your digital connection cable from the service provider side to the T1/E1/J1 external port on HA100.

4. **For LAN connection:** Connect one end of the Ethernet cable to the LAN external port on HA100 and the other end to a switch, hub or etc.

Connecting the HA100 with 2x UCM6510s

In a connection between HA100 and 2x UCM6510s, one UCM6510 will function as the primary server and provide online services. The other UCM6510 will function as a backup server and will not provide services until the primary server is down.

Setup Requirements

The internal connection setup will require the following items:

- 5 RJ45 cables (Ethernet).
- 2 RJ48 cables (T1/E1/J1).
- 8 RJ11 cables (If using PSTN trunks and/or analog devices)..
- 2 USB-to-RS485 serial cables.
- 2 UCM6510 (UCM A and UCM B) using firmware 1.0.15.13 or higher.

UCM6510 and HA100 Connection

Please refer to followings steps for the basic internal connections between HA100, UCM A(Master) and UCM B(Slave):

1. Connect respectively UCM A's Line port (FXO), Phone port (FXS), E1/T1/J1 port, WAN port and LAN port to HA100's FXO-A port, FXS-A port, E1/T1/J1-A port, WAN-A port, and LAN-A port.
2. Use the USB-to-RS485 serial cable to connect UCM A's USB port to the RS485-A port on HA100.
3. Connect respectively UCM B's Line port (FXO), Phone port (FXS), E1/T1/J1 port, WAN port and LAN port to HA100's FXO-B port, FXS-B port, E1/T1/J1-B port, WAN-B port, and LAN-B port.
4. Use the USB-to-RS485 serial cable to connect UCM B's USB port to the RS485-B port on HA100.
5. Use Ethernet cable to connect the Heartbeat ports on Primary UCM A and Backup UCM B.

Note: Since the UCM6510 has only one USB port, users are recommended to use a USB hub if they want to use an external USB storage device along with the HA100 module.

The following diagram illustrates the connection between the HA100 and 2 UCM6510 PBXs.



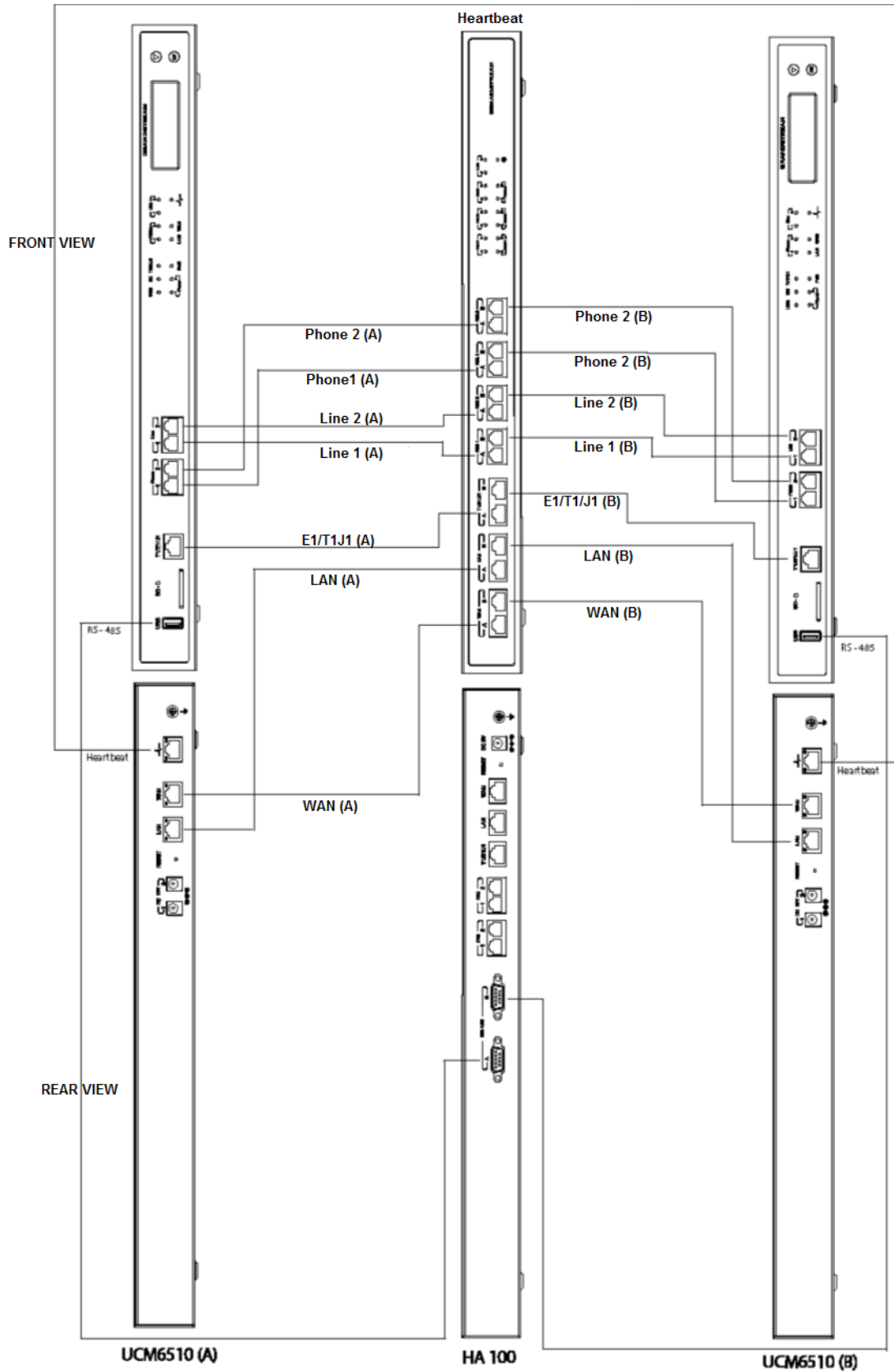

Figure 3: HA100 Connection with UCM A and UCM B

HA100 Deployment Methods

There are two deployment methods for adding an HA100 and a secondary UCM6510 to an existing UCM6510 setup:

Method 1: Backup and Restore Configuration

- **Step 1:** Upgrade UCM A to firmware version 1.0.15.13 or higher, and create a full backup (backup_A).
- **Step 2:** Upgrade UCM B to the same firmware as UCM A, and "backup_A" to UCM B. UCM A and UCM B should now have same configuration and data.
- **Step 3:** Connect all the cables as described in **[UCM6510 and HA100 Connection]** section "HA100 Connection". Make sure all ports A in HA100 are connected to UCM A, and all ports B are connected to UCM B.
- **Step 4:** Make sure UCM A, UCM B and HA100 are up and running. Access UCM_A's web UI, enable HA under *System Settings*→*HA*.
- **Step 5:** Save and apply changes before rebooting.

Method 2: Sync Configuration

- **Step 1:** Upgrade UCM A to firmware version 1.0.15.13 or higher, then make a full backup (backup_A).
- **Step 2:** Upgrade UCM B to same firmware as UCM A.
- **Step 3:** Setup the connections as described in the **[UCM6510 and HA100 Connection]**, EXCEPT heartbeat connection between UCM A and UCM B.
- **Step 4:** Access UCM_A's web UI, enable HA under *System Settings*→*HA* and reboot UCM A.
- **Step 5:** Establish the heartbeat connection between UCM A and UCM B. UCM A should now sync its configuration to UCM B.



HA100 FUNCTIONALITY

HA100 separates the external ports into the corresponding internal ports (A and B). Only one UCM6510 device is connected at any given time.

When the 2 UCM6510s connect to HA100 via port A and port B, the primary UCM6510 will use the external ports on HA100 for data transmission. The HA100's RS485 port receives signaling from the UCM6510s to switch between Port A and Port B.

If the internal port A on HA100 is connected successfully to the corresponding port on primary UCM6510, the LED indicator for port A on HA100 will be solid green. The primary UCM6510 relies on HA100's external ports for connections. In this case, the LED indicator for Port B on HA100 will not light up, and the backup UCM will not provide service.

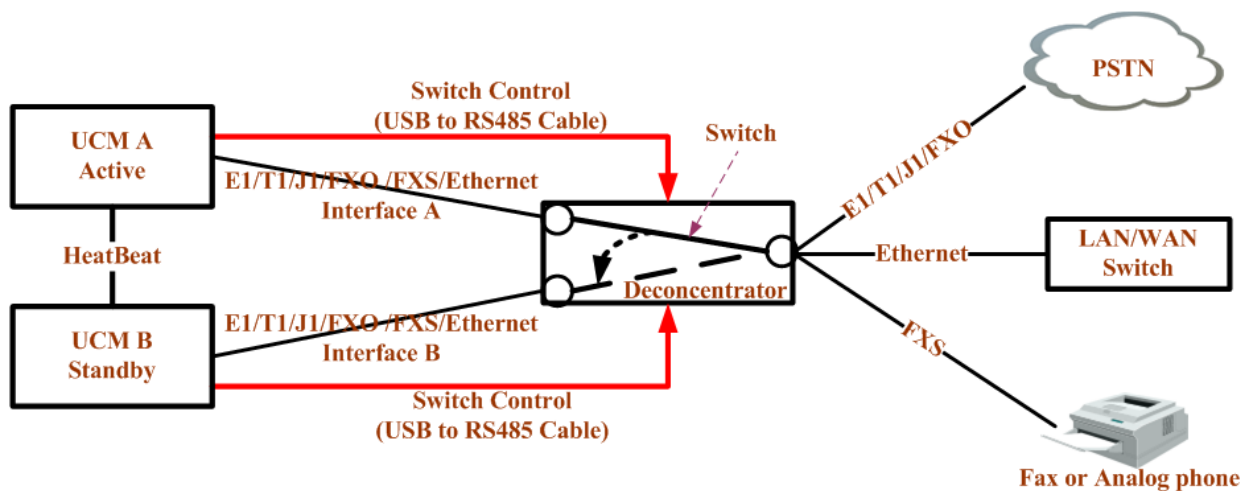

Figure 4: HA100 Functionality

For more details about UCM6510, please refer to online User Manual:

http://www.grandstream.com/sites/default/files/Resources/ucm6510_usermanual.pdf

UCM6510 Failure Management

If the primary server (UCM6510 A) detects issues within itself, it will signal the HA100 via USB-to-RS485 cable to switch connection from Port A to Port B. The backup server (UCM6510 B) will then be successfully connected and resume service. If the primary server is suddenly down for any reason, the HA100 will automatically switch the connection from Port A to Port B, allowing the backup server (UCM6510) to resume services and minimizing the impact of the interruption.

HA100 Failure Management

The failure of HA100 will not cause the whole system to go down automatically.

The system will only go down if UCM master **and** UCM slave fail **or** UCM master **and** HA100 fail. For example, in a typical installation, UCM A is the master and UCM B is the slave. When HA100 goes down, it will not impact UCM A's operation. And UCM A will detect that the HA100 is down and will send out alarm notifications via email. In this scenario, the whole network environment will be down if UCM A's connections are lost. The HA100 setup should be reestablished before this happens.

Important Notes

- When primary-secondary switchover happens, active call will be cut off and cannot be recovered.
- Switchover will occur when both WAN and LAN connections are lost.
- When hardware scan and failure switchover are selected, the UCM will scan the selected interfaces. If failures are detected, the HA100 will perform primary-secondary switchover. For example, when hardware scan and failure switchover are selected for FXO, and the FXO cable is disconnected, it will trigger a switchover.
- For FXS port failure scan, the UCM will perform switchover only when there is an FXS chip hardware error and not when an FXS cable is disconnected.
- In a scenario where there is a persisting issue that triggers constant switchover, no switchovers will occur beyond the second one.
- Failure detection will detect only hardware failures.
- Data in external storage devices will not sync.
- If a switchover occurs, and UCM B assumes the Master role, UCM B will remain as Master until another switchover occurs.
- When upgrading UCM firmware, both UCM A and UCM B will be upgraded in the process. Both devices will reboot upon successful upgrade.

